

内容见附件

警告:

1、本图尺寸数字属制度单位(如无特殊标注, 均为mm)
The size of this figure belongs to the system unit (if no special annotation, all are mm.)
2、不得已比例量度图上尺寸, 一切尺寸以图上数字为准。
All dimensions are subject to the figures on the drawing.
3、生产单位详细核对产品实际尺寸与图示数字, 如有偏差应及时通知该项目设计师, 在做出相应调整后方可制作。
The production unit shall check the actual size and figure of the product in detail. If there is any deviation, please inform the project designer in time and make the corresponding adjustment.

4、制作时颜色应用应严格按照图示给出的潘通色或CMYK值进行制作, 如有疑问应及时联系项目设计师, 确认无误后方可制作。
The color application should be made in strict accordance with the pantone color or CMYK value shown in the diagram. If there is any doubt, please contact the project designer in time and make sure that it can be made after confirmation.
5、此图纸只有在相关人员审核后方可正式应用于生产, 否则后果自负。
This drawing can only be formally applied to production after the approval of the relevant personnel, otherwise the consequences will be overconfident.

产品名称 Product Name:
PX-FM系列英文说明书

日期 Date:
2023.12.05

产品编码 Item No:
2340300301

产品版面 Product layout:
V1.2

设计 Designer:
Allen

审核 Review:

AKUSENSE

Laser Distance Sensor
PX-FM SERIES



User's manual

Thank you for choosing AKUSENSE. Please read the manual carefully before using this product.

- The product should be applied by someone with a certain level of electrical knowledge.
- Please read and make sure that you understand how to operate the product before using it.
- Please keep this manual readily accessible for future reference when needed.

WARNING

Please comply with the warnings indicated below for they are important.

- Please do not exceed maximum rated voltage during usage in order to prevent tester malfunction or fire.
- Please do not apply AC power supply to avoid breakage.
- Please do not subject the product to high temperature to avoid scalding.

SAFETY PRECAUTIONS

For your safety, please comply with the tips listed below.

- Please do not use it in flammable or explosive environments.
- Please do not use it in environments with water, oil, chemicals or steams.
- Please do not disassemble, repair or alter this product.
- Please do not exceed the rated voltage and current.
- Please do not exceed the rated environment.
- Please observe electrical polarity when making connections.
- Please connect load correctly.
- Please avoid short-circuiting the load.
- Please do not operate it, if the housing is broken.
- When disposing the tester, please treat it as an industrial waste.

LASER STANDARD

- Laser standard: IEC 60825-1 ed2.0; level 2
Note: Do not look at the laser light source, it may cause eye



PACKAGE CONTENTS

- Sensor 1pcs
- User's manual 1pcs

SPECIFICATION

Model	PX-FM08-485	PX-FM08-IV-232	PX-FM08-232
	PX-FM40-485	PX-FM40-IV-232	PX-FM40-232
	PX-FM80-485	PX-FM80-IV-232	PX-FM80-232
Sensing distance	PX-FM08: 0.05~8m; PX-FM40: 0.05~40m; PX-FM80: 0.05~80m		
Resolution	1mm		
Repeat accuracy	$\pm 2\text{mm}$		
Laser type	630-670nm, Class II, $\leq 1\text{mW}$		
Mode	Single measurement / Continuous measurement / Quick measurement		
Response time	Single measurement: 1s Continuous measurement: 200ms Quick measurement: 30-100ms		
Material	Aluminum alloy		
Weight	200g		
Mounting	2-M3*3 screws		
Operating temperature	-10°C~40°C		
Storage temperature	-20°C~60°C		
Humidity	Up to 95%, no condensation, temperature 40°C		
Ambient light	0~10000Lux		
Operating voltage	PX-FM08(80)-485 / PX-FM08(80)-IV-232: 24VDC $\pm 10\%$ PX-FM40-485 / PX-FM40-IV-232: 12~26VDC		5VDC $\pm 10\%$
Current consumption	Normal 44mA, max. 65mA		Normal 50mA, max. 150mA
Serial communication	RS485(Modbus)	RS232/4-20mA/0-10V	RS232
Input voltage	-		Active low
Output voltage	Active low	Active low, 2 channel output	Active low
Cable	2m cable		1m cable

CIRCUIT DIAGRAM

PX-FM08(80)-485

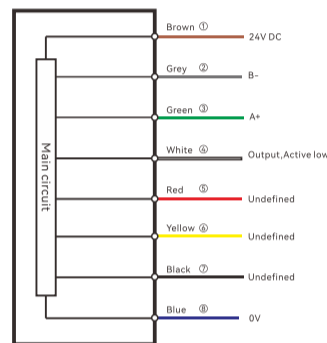

PX-FM08(80)-IV-232

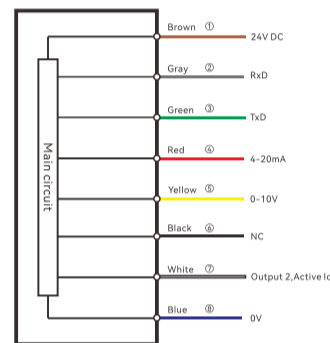

PX-FM08(40/80)-232

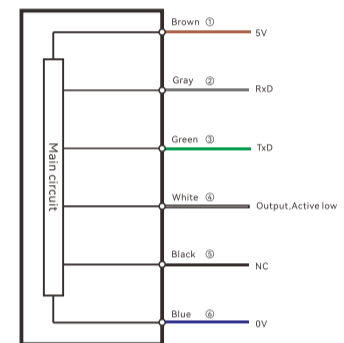

PX-FM40-485

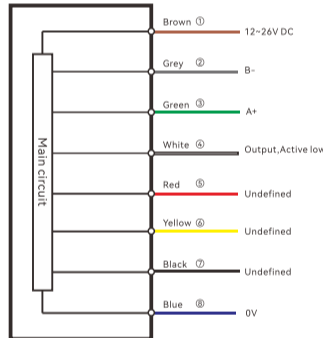

PX-FM40-IV-232

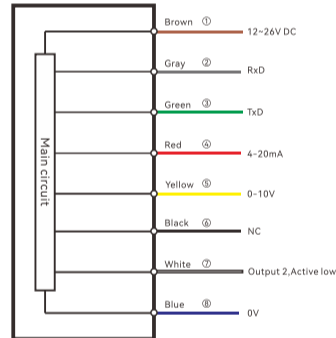

Function	Operation	Indicator	Notes
Set D2	Short press on the right button (time shorter than 1s), each time reduce by 0.01m. Long press on the right button, set the value to decrease by 0.5m.	flash	The background of LINE D2 is white, indicating that D2 is being set up. It shows "SETTING" on the third line.
Exit Setup	Long press on the key SET (3-10s)	Flash stop	D1&D2 are always on and it shows the setting values. Real-time measurement values displayed on the third line.

OPERATING INSTRUCTION

The laser distance sensor enters the real-time measurement within 3 seconds after powering up, and OLED displays the set values of D1 (proximity value) and D2 (distance value), as well as the current measurement value on the third line. You can set the close detection point (D1) and remote detection point (D2) via the control panel. If more settings are required, need to be set via commands. The setting steps presented as follows:

function	button	OUTPUT instructor	display	picture
Enter Setup	Long press the SET button (3-10s). Long press the SET button (3-10s). First set D1, short press it (0.3-1s) to toggle D1/D2, through the flashing signal on display to complete the switch.	flash	When D1/D2 flashes, it can be set and it shows "SETTING" on the third line.	
Set D1	Short press on the left button (time shorter than 1s), each time increase by 0.01m. Long press on the left button, increase the setting value by 0.5m.	flash	The background of LINE D1 is white, indicating that D1 is being set up. It shows "SETTING" on the third line.	
	Short press on the right button (time shorter than 1s), each time reduce by 0.01m. Long press on the right button, set the value to decrease by 0.5m.	flash	The background of LINE D1 is white, indicating that D1 is being set up. It shows "SETTING" on the third line.	
Set D2	Short press on key "SET" (time shorter than 1s) to switch to D2.	flash	The background of LINE D2 is white, indicating that D2 is being set up. It shows "SETTING" on the third line.	
	Short press on the left button (time shorter than 1s), each time increase by 0.01m. Long press on the left button, increase the setting value by 0.5m.	flash	The background of LINE D2 is white, indicating that D2 is being set up. It shows "SETTING" on the third line.	

SOFTWARE NOTE

RS232 communication port

The Laser Distance Measuring Sensors take RS232 communication with the following default parameter settings:

Function	Default Setting	Optional Setting
Function	9600	9600/19200/38400/57600/115200
data bit	8	8
parity bit	n	n
stop bit	1	1

Data format: prefix + command or barcode content + suffix

	ASCII	hexadecimal system
prefix	<STX>	02
suffix	<CR><LF>	0D 0A

Frequently used commands

command	ASCII	hexadecimal system
Turn on single measurement	<STX>+<CR><LF>	02 2B 0D 0A
Turn on continuous measurement	Function: Laser distance sensor returns single measurement data.	
	<STX>C+<CR><LF>	02 43 2B 0D 0A
Turn on fast continuous measurement	Function: After receiving the command, first back to the confirm value " <STX>PS0<CR><LF> ". The laser distance sensor enters the continuous output mode and continuously transfers the measured value to the serial port.	
	<STX>C++<CR><LF>	02 43 2B 2B 0D 0A
Turn off continuous measurement	Function: After receiving the command, first back to the confirm value " <STX>PS0<CR><LF> ". Laser distance sensor exits continuous measurement.	
	<STX>C-<CR><LF>	02 43 2D 0D 0A
Search	Function: Back to the internal firmware information of the laser distance sensor. Used to test if the code reader is in a connected state or not.	<STX>V<CR><LF>

Set baud rate to 9600	<STX>SBD=9600<CR><LF>	02 53 42 44 3D 39 36 30 30 0D 0A	Function: After receiving the command, first back to the confirm value " <STX>PS0<CR><LF> ". Port baud rate of laser distance sensor change to 9600.
Set baud rate to 19200	<STX>SBD=19200<CR><LF>	02 53 42 44 3D 31 39 32 30 30 0D 0A	Function: After receiving the command, first back to the confirm value " <STX>PS0<CR><LF> ". Port baud rate of laser distance sensor change to 19200.
Set baud rate to 38400	<STX>SBD=38400<CR><LF>	02 53 42 44 3D 33 38 34 30 30 0D 0A	Function: After receiving the command, first back to the confirm value " <STX>PS0<CR><LF> ". Port baud rate of laser distance sensor change to 38400.
Set baud rate to 57600	<STX>SBD=57600<CR><LF>	02 53 42 44 3D 35 37 36 30 30 0D 0A	Function: After receiving the command, first back to the confirm value " <STX>PS0<CR><LF> ". Port baud rate of laser distance sensor change to 57600.
Set baud rate to 115200	<STX>SBD=115200<CR><LF>	02 53 42 44 3D 31 31 35 32 30 30 0D 0A	Function: After receiving the command, first back to the confirm value " <STX>PS0<CR><LF> ". Port baud rate of laser distance sensor change to 115200.
Set proximity detection point D1	<STX>D1=xxxxx<CR><LF>	02 44 31 3D xxxxx 0D 0A	Function: After receiving the command, first back to the confirm value " <STX>PS0<CR><LF> ". Set the proximity value for the detection range. Value ranges from 00000 to 80000 mm. D1<D2. When the measured value is between D1~D2, the output voltage pulled down. Analog output range for current and voltage is (D1-D2).
	<STX>D2=yyyyy<CR><LF>	02 44 32 3D yyyyy 0D 0A	Function: After receiving the command, first back to the confirm value " <STX>PS0<CR><LF> ". Set the remote value of the detection range. Value ranges from 00000 to 80000 mm. D2>D1. When the measured value is between D1~D2, the output voltage pulled down. Analog output range for current and voltage is (D1-D2).

RS485 communication port

The ODS Laser Distance Measuring Sensors take RS232 communication with the following default parameter settings:

Function	Default Setting
Baud rate	9600
Data bit	8
Parity bit	n
Stop bit	1

Protocol: Modbus

The protocol instructions are divided into: 04H instruction (read input register) and 10H instruction (write multiple holding registers).

The format of the 04H instruction is as follows:

04H instruction (read input register)				
1 Communication frame format				
1byte	1byte	2byte	2byte	2byte
Address code	Function code	Register address	Number of registers N	CRC
2 Response frame format				
1byte	1byte	1byte	2N byte	2byte
Address code	Function code	Number of bytes 2N	Register address	CRC

3 Error frame format				
1byte	1byte	1byte	2byte	
Address code	Error code	Exception code	CRC	

The 04H instruction mainly includes the following commands:
Obtain single measurement data and query the version number

Upper computer command					
Function description	Address code	Function code	Register address	Number of registers N	CRC
Obtain single measurement data	0x01	0x04	0x0000	0x0002	0x71CB
Query the version number	0x01	0x04	0x0120	0x0020	0xF1E4

Laser displacement sensor response				
Address code	Function code	Number of bytes 2N	Register value	CRC
0x01	0x04	0x04		
0x01	0x04	0x40		

Remark:

Single output measurement value
Sensor version number

Examples are as follows:
Obtain single measurement data and issue commands: 01 04 00 00 02 71 CB
Return: 01 04 04 00 02 2D 3A F9
Calculate: 0x00 00 02 2D= 557. Then the actual measured value is 0.557m

The format of the 10H instruction is as follows:

10H instruction (write multiple holding registers)						
1 Communication frame format						
1byte	1byte	2byte	2byte	1byte	N*2 byte	2byte
Address code	Function code	Register address	Number of registers N	Number of bytes 2N	Register value	CRC
2 Response frame format						
1byte	1byte	2byte	2byte	2byte		
Address code	Function code	Register value	Number of registers N	CRC		
3 Error frame format						
1byte	1byte	1byte	2byte			
Address code	Error code	Exception code	CRC			

Upper computer command							
Function settings	Address code	Function code	Register address	Number of registers	Number of bytes	Register value	CRC
Setting D1 (Short range value, less than 40m)	0x01	0x10	0x0010	0x0002	0x04		
Setup D2 (Long distance value, less than 40m, D1 < D2)	0x01	0x10	0x0012	0x0002	0x04		
Set slave address (slave address range 00 01 ~ 00 FF)	0x01	0x10	0x0004	0x0001	0x02		

Laser displacement sensor response				
Address code	Function code	Register address	Number of registers	CRC
0x10	0x10	0x0010	0x0002	
0x01	0x10	0x1200	0x0002	

Examples are as follows:							
Setting D1=0.1m	0x01	0x10	0x0010	0x0002	0x04	0x00 00 00 64	0xF348
Setting D1=1.0m	0x01	0x10	0x0012	0x0002	0x04	0x00 00 03 E8	0x73C4
Setting the slave address from 01 to 02:00 02	0x01	0x10	0x0004	0x0001	0x02	0x0002	0x2615
Setting the slave address from 02 to 01: 00 01	0x02	0x10	0x0004	0x0001	0x02	0x0001	0x72E4

Remark: You need to convert m into mm for calculation.													
01	10	00	10	00	02	04	00	00	00	64	F3	48	Set to 0.1 meters, that is, 100mm=0000 0064
01	10	00	12	00	02	04	00	00	03	E8	73	C4	Set to 1.0 meters, that is, 1000mm=0000 03E8

ERROR CODE

The displacement sensor detects the internal status in real time and displays the error code on the display screen.

Error code	Error content
E252	Temperature is too high
E253	Temperature is too low
E255	The reflected signal is too weak
E256	The reflected signal is too strong
E258	Out of range
E285	Photosensitive receiving device abnormality
E286	Laser emitting device abnormality
E290	Motherboard abnormality

ANALOG OUTPUT

PX-FM08/40/80-IV-232 contains both current analog (I) and voltage analog (V) outputs.

Current analog I (4-20mA)

The current analog output is linearly related to the set range of D1-D2. D1/D2 set by the buttons mentioned above, or by command.

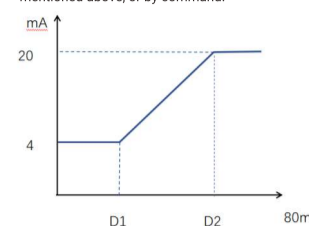

Voltage analog V (0-10V)

The voltage analog output is linearly related to the set range of D1-D2. D1/D2 set by the buttons mentioned above, or by command.

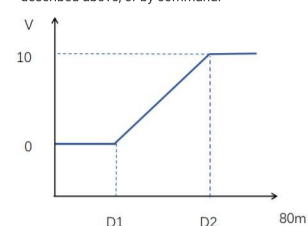

WARRANTY

Warranty period

- The product warranty period is one year, from the date of delivery of the product to the date of purchase.

Warranty range

- AKUSENSE will repair the product free of charge if there is a malfunction caused by AKUSENSE Company in the above warranty period. But the following is not covered by the warranty.
 - Not in accordance with the operating instructions, the user manual or the purchaser and the AKUSENSE company specifically reached the technical requirements of the conditions specified in the environment under the incorrect operation, or improper use of appropriate failure.
 - Failure is not due to product defects, but the purchaser equipment or the purchaser software design caused.
 - Malfunctions caused by modifications or repairs by non-Akuseense company personnel.
 - In accordance with the operating instructions or user manual correct repair or replacement of wearing parts and other provisions can be completely avoided failure.
 - In the product from the AKUSENSE company after delivery, due to unpredictable changes in science and technology and other factors caused by the failure.
 - Due to fire, earthquake and floods and other natural disasters, or abnormal voltage and other external factors caused by the fault AKUSENSE company is not responsible for the warranty.
- The warranty is limited to the conditions specified in Article (1), and AKUSENSE Company shall not be liable for any indirect loss (damage to equipment, loss of opportunity, loss of profits, etc.) or other loss caused by its equipment.